



Designation: C827/C827M – 23

Standard Test Method for Change in Height at Early Ages of Cylindrical Specimens of Cementitious Mixtures¹

This standard is issued under the fixed designation C827/C827M; the number immediately following the designation indicates the year of original adoption or, in the case of revision, the year of last revision. A number in parentheses indicates the year of last reapproval. A superscript epsilon (ϵ) indicates an editorial change since the last revision or reapproval.

1. Scope*

1.1 This test method covers the determination of change in height of cylindrical specimens from the time of molding until the mixture is hard.

1.2 This test method covers height change measurements at early ages for cementitious mixtures of paste, grout, mortar, and concrete.

1.3 This test method is intended for determination of changes in height that occur from the time of placement until the specimen is fully hard. These include shrinkage or expansion due to hydration, settlement, evaporation, and other physical and chemical effects.

1.4 The values stated in either SI units or inch-pound units are to be regarded separately as standard. The values stated in each system are not necessarily exact equivalents; therefore, to ensure conformance with the standard, each system shall be used independently of the other, and values from the two systems shall not be combined.

1.5 The text of this test method refers to notes and footnotes that provide explanatory information. These notes and footnotes shall not be considered as requirements of the test method.

1.6 *This standard does not purport to address all of the safety concerns, if any, associated with its use. It is the responsibility of the user of this standard to establish appropriate safety, health, and environmental practices and determine the applicability of regulatory limitations prior to use. (Warning—Fresh hydraulic cementitious mixtures are caustic and may cause chemical burns to exposed skin and tissue upon prolonged exposure.²)*

1.7 *This international standard was developed in accordance with internationally recognized principles on standard-*

¹ This test method is under the jurisdiction of ASTM Committee C09 on Concrete and Concrete Aggregates and is the direct responsibility of Subcommittee C09.68 on Volume Change.

Current edition approved June 15, 2023. Published July 2023. Originally approved in 1975. Last previous edition approved in 2016 as C827 – 16. DOI: 10.1520/C0827_C0827M-23.

² See Section on Safety Precautions, Manual of Aggregate and Concrete Testing, Annual Book of ASTM Standards, Vol. 04.02.

ization established in the Decision on Principles for the Development of International Standards, Guides and Recommendations issued by the World Trade Organization Technical Barriers to Trade (TBT) Committee.

2. Referenced Documents

2.1 ASTM Standards:³

- C125 Terminology Relating to Concrete and Concrete Aggregates
- C138/C138M Test Method for Density (Unit Weight), Yield, and Air Content (Gravimetric) of Concrete
- C143/C143M Test Method for Slump of Hydraulic-Cement Concrete
- C185 Test Method for Air Content of Hydraulic Cement Mortar
- C191 Test Methods for Time of Setting of Hydraulic Cement by Vicat Needle
- C192/C192M Practice for Making and Curing Concrete Test Specimens in the Laboratory
- C305 Practice for Mechanical Mixing of Hydraulic Cement Pastes and Mortars of Plastic Consistency
- C403/C403M Test Method for Time of Setting of Concrete Mixtures by Penetration Resistance
- C670 Practice for Preparing Precision and Bias Statements for Test Methods for Construction Materials
- C807 Test Method for Time of Setting of Hydraulic Cement Mortar by Modified Vicat Needle
- C939/C939M Test Method for Flow of Grout for Preplaced-Aggregate Concrete (Flow Cone Method)
- C953 Test Method for Time of Setting of Grouts for Preplaced-Aggregate Concrete in the Laboratory
- C1437 Test Method for Flow of Hydraulic Cement Mortar

3. Terminology

3.1 *Definitions*—The terms used in this test method are defined in Terminology C125.

3.2 *Definitions of Terms Specific to This Standard:*

³ For referenced ASTM standards, visit the ASTM website, www.astm.org, or contact ASTM Customer Service at service@astm.org. For *Annual Book of ASTM Standards* volume information, refer to the standard's Document Summary page on the ASTM website.

*A Summary of Changes section appears at the end of this standard

3.2.1 *early-age change in height, n*—the measured increase or decrease in height of a laterally confined cylindrical test specimen from the time of molding to when the mixture becomes hard. The user may want to define this age as the time when a companion specimen of the same batch has reached the time of final setting by Test Method C191 (paste), C953 (mortar or grout), C403/C403M (concrete), or establish a predetermined age in minutes from the time the specimen is cast as the defined age to record the final measurement. Changes in height are measured and expressed as a positive or negative change in the height of a test specimen that is restrained from lateral movement.

4. Significance and Use

4.1 This test method provides a means for comparing the relative shrinkage or expansion of cementitious mixtures. It is particularly applicable to grouting, patching, and form-filling operations where the objective is to completely fill a cavity or other defined space with a freshly mixed cementitious mixture that will continue to fill the same space at time of hardening. It would be appropriate to use this test method as a basis for prescribing mixtures having restricted or specified volume change before the mixture becomes hard.

4.2 This test method can be used for research purposes to provide information on volume changes taking place in cementitious mixtures between the time just after mixing and the time of hardening. However, the specimen used in this test method is not completely unrestrained so that the measurements are primarily useful for comparative purposes rather than as absolute values. Further, the degree of restraint to which the specimen is subjected varies with the viscosity and degree of hardening of the mixture.

5. Apparatus (see Fig. 1)

5.1 *Projected Light Source*, a lamp and a condensing lens of sufficient intensity to adequately project a light beam on a wall about 5 m [15 ft] from the light source. Protect the test specimen from heat from the light source and limit air movement (Note 1).

NOTE 1—Placing a sheet of transparent glass or plastic between the light source and the test specimens may be beneficial.

5.2 *Indicator Ball*, a spherical ball of nonabsorptive material with a density that is 55 % ± 5 % of the density of the cementitious mixture being tested, having a diameter not more

than 16 mm [5/8 in.] nor less than 6 mm [1/4 in.], and composed of materials that have no reaction with the cementitious mixture during the test period.⁴

NOTE 2—A density of approximately 1.2 Mg/m³ has been found appropriate for most uses of this test method. The density of the cementitious mixture may be calculated from values for “unit weight” obtained using Test Method C138/C138M (concrete) or C185 (mortar, grout, or paste).

5.3 *Magnifying Lens System*, a magnifying lens system such that the image of the indicator ball produced by the projected light source is cast on the indicating chart about 5 m [15 ft] away at a magnification of 90× to 110×, mounted so as not to touch the test specimen when a test is in progress (see Note 3), and having a separate magnifying lens system for each specimen tested simultaneously.

NOTE 3—One magnifying lens system that has been found acceptable consists of two lenses: a projection and a relay lens enclosed in a sealed tube. In this system, the relay lens is located nearer the test specimen and has a focal length of 50.8 mm [2 in.] and is located approximately 115 mm [4½ in.] from the indicator ball. The projection lens has a focal length of 41.4 mm [1⅝ in.], and relative aperture of f1.6 and is 133.1 mm [5¼ in.] from the relay lens.

5.4 *Indicating Charts*, composed of stiff material approximately 600 mm [24 in.] high by 250 mm [10 in.] wide, with a white surface and a vertical black line 2 mm [1/16 in.] wide, centered and running the complete length of the chart, and a horizontal black line 1 mm [1/32 in.] in width midway on the chart, identified as the zero (0) or starting line, and 2 mm [0.1 in.] horizontal graduations above and below the zero line on the entire length of the vertical line, and a means for attaching this chart vertically and firmly to a distant wall.

5.5 *Molds*, rigid, watertight molds with a smooth interior surface made of steel, cast iron, or other nonabsorbent material nonreactive with the cementitious mixture being tested, cylindrical in shape, with internal height twice the internal diameter. Three sizes of molds are used in this test method with heights of 100 mm, 150 mm, 300 mm [4 in., 6 in., 12 in.].

5.6 *Rods*, two straight, steel tamping rods: one 10 mm [3/8 in.] in diameter and approximately 300 mm [12 in.] in

⁴ An 11 mm [7/16 in.] nylon plastic indicator ball has been found acceptable for most tests and is available from U.S. Plastics Corp., 1390 Neubrecht Rd., Lima, OH 45801.

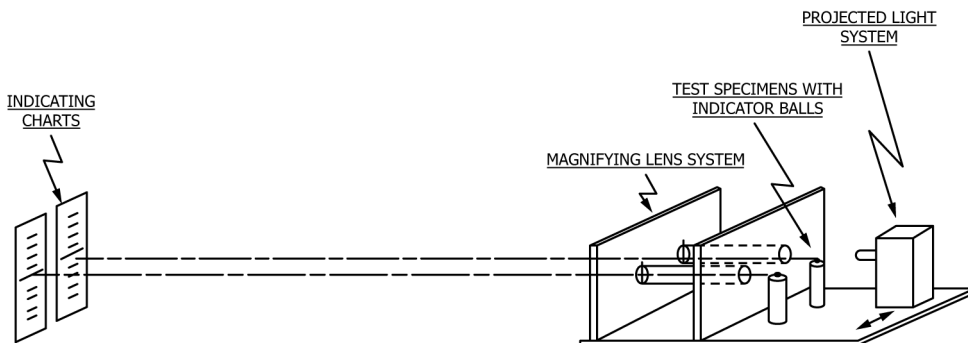

FIG. 1 Apparatus for Early Change in Height